



RoboLabs

Incredible machines for fastfood & funfood

Caramel coating machine SugarLips 100 (CP-100SU)

208 V 60 Hz

Technical manual



Read this manual before use and keep for future reference!

PDF version of this manual is available on www.robolabs.pro

Safety requirements



This is the safety alert symbol. It is used to alert you to potential physical injury hazards. Obey all safety messages that follow this symbol to avoid possible injury or death.

DANGER



- **THIS MANUAL IS FOR SKILLED TECHNICIANS ONLY!**
- **DO NOT** open electric panels unless you are qualified for this.
- **Electric shock hazard!** High voltage inside electric panel. **DO NOT** touch bare terminals and/or wires.
- **ALWAYS** unplug the machine before servicing, unless you need it to be energized for performing setup procedures.

WARNING



- **Burn hazard!** Some parts of machine are very hot. Wait until machine is cooled down before working with those parts.

WARNING



- **ALWAYS** wear eye protection while servicing this equipment to avoid possible injury.

Contents

1	Components setup	3
1.1	Temperature regulator setup	3
1.2	Temperature limiter setup	4
1.3	VFDs setup	5
2	Diagnostic procedures	6
2.1	Temperature regulator (DC3)	6
2.2	Main temperature sensor (BT2)	7
2.3	Temperature Limiter (DC4)	7
2.4	Limiting temperature sensor (BT1)	7
2.5	Inductive relay (K)	7
2.6	Solid-state relays (VS1-VS4)	8
2.7	Heating elements (EK1-EK6)	8
2.8	Power supply unit (PSU)	9
2.9	Proximity sensors (BL1, BL2)	9
2.10	Contactors (KM2)	9
2.11	Switch (SA1)	10
2.12	Circuit breaker (QF)	10
2.13	VFD units (UZ1, UZ2)	11
2.14	Motors (M1, M2)	12
2.15	Fans (MF1,MF2)	13
3	Parts list	14

1 Components setup

1.1 Temperature regulator setup

Temperature regulator TCN4S (Fig.1) has three setting groups: 1st setting group, 2nd setting group, and SV setting group (the main indication mode). The settings must be changed in the same order as they appear in the list. Note that after changing **In-t** (temperature sensor type) or **UnI-t** (temperature unit) values, parameters **H-Su**, **L-Su**, **AL1**, **AL2**, **AHYS** must be set again. The regulator has more parameters than listed below; if you see a parameter not from the list, skip it and move to the next one.

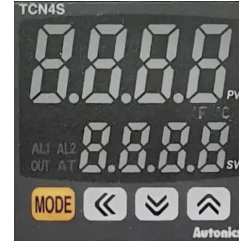

Figure 1: TCN4S panel

Parameters changing procedure

1. To access the 2nd group of parameters press and hold **MODE** for 4 seconds; once display reads **PAR2**, release **MODE**.
2. To access the 1st group of parameters, press and hold **MODE** for 2 seconds; once display reads **PAR1**, release **MODE**.
3. Press **MODE** to go through the parameters. Current value is represented on the lower line of the display.
4. Press **↑** or **↓** to change the value.
5. Press **MODE** to move to the next parameter.

Group	Param	Value	Description
2nd	LoC	oFF	Unlock all settings for changing
2nd	In-t	YCA.H	Temperature sensor type
2nd	L-Su	90	SV low-limit value, °C
2nd	H-Su	220	SV high-limit value, °C
2nd	C-nd	PId	Control type
2nd	oUt	SSr	Control output
2nd	AL-1	An1.A	AL1 alarm operation mode
2nd	AHYS	10	Alarm output hysteresis, °C
1st	AL1	-10	AL1 alarm temperature, °C
1st	P	200	Proportional band, °C
1st	I	0	Integral time
1st	d	0	Derivative time
2nd	LoC	LoC2	Group 1 and 2 settings locked
SV	SV	155	Default temperature, °C

1.2 Temperature limiter setup

DANGER



- **Electric shock hazard!** High voltage inside electric panel. DO NOT touch bare terminals and/or wires.

TC4SP unit (Fig.2) has three setting groups: 1st setting group, 2nd setting group, and SV setting group (the main indication mode). The settings must be changed in the same order as they appear in the list. Note that after changing **In-t** (temperature sensor type) or **UnI-t** (temperature unit) values, parameters **H-Su**, **L-Su**, **AL1**, **AL2**, **AHYS** must be set again. The regulator has more parameters than listed below; if you see a parameter not from the list, skip it and move to the next one.

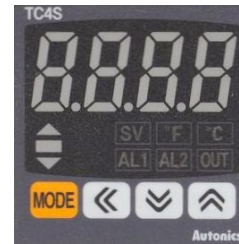

Figure 2: TC4SP panel

Parameters changing procedure

1. To access the 2nd group of parameters press and hold **MODE** for 4 seconds; once display reads **PAR2**, release **MODE**.
2. To access the 1st group of parameters, press and hold **MODE** for 2 seconds; once display reads **PAR1**, release **MODE**.
3. Press **MODE** to go through the parameters. Press **←** to see current value of the parameter.
4. Press **↑** or **↓** to change the value.
5. Press **MODE** to move to the next parameter.

Group	Param	Value	Description
2nd	LoC	oFF	Unlock all settings for changing
2nd	In-t	YCA	Temperature sensor type
2nd	L-Su	250	SV low-limit value, °C
2nd	H-Su	400	SV high-limit value, °C
2nd	C-nd	onoF	Control type
2nd	oUt	rLY	Control output
1nd	HYS	10	Alarm output hysteresis, °C
SV	SV	350	Default temperature, °C
2nd	LoC	LoC3	All settings locked

1.3 VFDs setup

⚠ DANGER



- **Electric shock hazard!** High voltage inside electric panel. DO NOT touch bare terminals and/or wires.

NOTE 1: VFD setup must be performed only when the drive is stopped.

NOTE 2: After setting parameter 02.00 to 9, VFD displays **End**, and gets back to the main indication mode. After this, continue setup process from parameter 00.03.



Figure 3: VFD control panel

Parameters changing procedure

1. Locate the VFD control panel, see Fig 3.
2. To change or view parameter value, press **ENTER**, the display shows **00.00**.
3. Press **▲** or **▼** to choose the first two digits of the parameter (for example, 02).
4. Press **ENTER** again, display shows **02.00**.
5. Press **▲** or **▼** to choose the second two digits of the parameter, for example, **02.11**.
6. Press **ENTER** again to see the current value of the parameter. Change value, if needed, with **▲** or **▼**.
7. Press **ENTER** to confirm and save the new value, the display shows **End**.
8. Press **MODE** to return back to the previous level of selection or to the main mode.

Parameter	UZ1 (mixer)	UZ2 (kettle)	Description
00.02	9	9	Settings initialization
00.03	1	1	Start-up display selection
01.00	50.00	50.00	Maximum output frequency
01.09	2.0*	1.6*	Accel time
01.10	2.0*	1.6*	Decel time
01.16	0	4	Acceleration/deceleration mode
02.00	0	0	Source of first master frequency command: keypad
02.01	4	4	Source of first operation command: RS-485
02.04	0	0	Motor direction control
02.07	1	1	Up/down mode
02.11	30.0	30.0	Keypad frequency command
07.02	5.0	5.0	Torque compensation
09.00	1	2	VFD communication address
09.01	1	1	Transmission speed: 9600 bps
09.02	1	1	Transmission fault treatment (warn and ramp to stop)
09.04	1	1	Communication protocol: ASCII, 7, E, 1

* – needs to be set up individually on each machine.

2 Diagnostic procedures

DANGER



- **Electric shock hazard!** High voltage inside electric panel. DO NOT touch bare terminals and/or wires.
- ALWAYS unplug the machine before resistance measurement, or open circuit check, or circuit continuity check.

CAUTION



- Some diagnostic procedures requires to turn the heating on. Pour enough water in the kettle so to cover the kettle bottom before performing such procedures. Running heating with empty kettle might lead to kettle overheating.

NOTE: Refer to the wiring diagram and parts list to locate the components. Following designation is used in this section:

- (5)/DC1 – terminal no.5 of the component DC1.
- 1.15 – wire labelled “1.15”.

2.1 Temperature regulator (DC3)

1. Set the main switch to CAMEL.
2. Ensure DC3 display is lit up. IF not, ensure 208 VAC presents between (5)/DC3 and (6)/DC3. IF voltage DOES present, BUT the display doesn't lit, replace DC3. IF voltage DOES NOT present:
 - 2.1. Ensure continuity and terminal tightening for the wires: 1.11 1.10 1.9 1.8 1.2
1.1 1.0 2.7 2.6 2.5 2.9 2.2 2.1 2.0
 - 2.2. Check KM2 contactor.
 - 2.3. Check QF circuit breaker.
3. Ensure +24 VDC presents at (8)/DC3. IF voltage DOES NOT present:
 - 3.1. Ensure continuity and terminal tightening for the wires: 5.10 5.9 5.8 5.7 5.6 5.5
5.4 5.3 5.2 5.1 5.0
 - 3.2. Check PSU power supply unit.
4. Ensure +24 VDC presents at (7)/DC3 whenever AL1 indicator on the DC3 display is on. IF voltage DOES NOT present, alarm output is fault, replace DC3.
5. Ensure +24 VDC DOES NOT present at (7)/DC3 whenever AL1 indicator on the DC3 display is off. IF voltage DOES present, alarm output is fault, replace DC3.
6. Ensure +24 VDC presents between (1)/DC3 and (2)/DC3 whenever the OUT indicator on the DC3 display is on. IF voltage DOES NOT present, SSR output is fault, replace DC3.

2.2 Main temperature sensor (BT2)

1. Unplug the machine. Wait until the kettle is cooled down to room temperature.
2. Ensure sensor wires are properly connected to (10)/DC3 and (11)/DC3.
3. Check the resistance between (10)/DC3 and (11)/DC3. It should be about 10 Ω . IF open circuit, replace the sensor.

2.3 Temperature Limiter (DC4)

1. Pour water in the kettle in the amount enough to cover the kettle bottom, to avoid overheating during following steps.
2. Set the main switch to CAMEL, and press HEATING.
3. Ensure 208 VAC presents between (10)/DC4 and (11)/DC4. IF voltage DOES present, BUT the display of DC4 doesn't lit, replace DC4. IF voltage DOES NOT present:
 - 3.1. Ensure continuity and terminal tightening for the wires: [1.8](#) [1.2](#) [1.1](#) [2.5](#) [2.9](#) [2.2](#) [2.1](#)
 - 3.2. Ensure J1 screw terminal continuity. Replace fault J1.
 - 3.3. Check KM2 contactor.
 - 3.4. Check QF circuit breaker.
4. Ensure DC4 proper set-up.
5. Ensure 230 VAC presents at (5)/DC4 whenever machine is in heating mode and OUT indicator is lit up. IF voltage DOES NOT present:
 - 5.1. Ensure continuity and terminal tightening for the wires: [1.14](#) [1.9](#) [1.8](#) [1.2](#) [1.1](#)
 - 5.2. Check KM2 contactor.
 - 5.3. Check QF circuit breaker.
 - 5.4. Check K relay.
6. Ensure 230 VAC presents at (4)/DC4 whenever machine is in heating mode and OUT indicator is lit up. IF voltage DOES NOT present, relay output is fault, replace fault DC4 temperature limiter.

2.4 Limiting temperature sensor (BT1)

1. Unplug the machine. Wait until the kettle is cooled down to room temperature.
2. Ensure sensor wires are properly connected to (2)/DC4 and (3)/DC4.
3. Ensure the resistance between (2)/DC4 and (3)/DC4 is about 10 Ω . IF open circuit, replace the sensor.

2.5 Inductive relay (K)

1. Unplug the machine.
2. Take out the relay's central module by pressing latching lever. Ensure the module pins and the socket are clean and free of dust and scrap. Insert the module back and fix with the orange latching lever.
3. Turn the machine on. Set the main switch to CAMEL, and press HEATING.

4. Ensure 230 VAC presents at (11)/K. IF voltage DOES NOT present:
 - 4.1. Ensure continuity and terminal tightening for the wires: [1.9](#) [1.8](#) [1.2](#) [1.1](#) [1.0](#)
5. Ensure 24 VDC presents at (A1)/K and (A2)/K. IF voltage DOES NOT present:
 - 5.1. Ensure continuity and terminal tightening for the wires: [6.11](#) [5.11](#) [5.10](#) [5.9](#) [5.8](#) [5.7](#) [5.6](#) [5.5](#) [5.4](#) [5.3](#) [5.2](#) [5.1](#) [5.0](#)
 - 5.2. Check PSU.
 - 5.3. Check that Y1 LED indicator on DC2 is lit up.
6. Ensure 230 VAC presents at (14)/K and (11)/K whenever 24 VDC presents at (A1)/K and (A2)/K. IF NOT, replace the relay.
7. Ensure 230 VAC DOES NOT present at (14)/K while there is no 24 VDC at (A1)/K and (A2)/K. IF NOT, replace the relay.

2.6 Solid-state relays (VS1-VS4)

1. Unplug the machine.
2. Ensure (1)/VSx and (2)/VSx are open. IF closed, replace VSx (where x is 1 to 4).
3. Pour water in the kettle in the amount enough to cover the kettle bottom, to avoid over-heating during following steps.
4. Turn the machine on. Set the main switch to CARMEL, and then press HEATING.
5. Ensure 230 VAC presents at (2)/VS1, (2)/VS2, (2)/VS3, (2)/VS4. IF voltage DOES NOT present:
 - 5.1. Ensure continuity and terminal tightening for the wires: [1.16](#) [1.17](#) [2.12](#) [2.13](#)
 - 5.2. Check KM1 contactor.
 - 5.3. Check QF circuit breaker.
 - 5.4. Check DC4 temperature limiter.
6. Ensure mains voltage presents at (1)/VS1, (1)/VS2, (1)/VS3, and (1)/VS4 whenever LED indicators on corresponding relays are lit up. IF voltage DOES NOT present, replace the fault relay.
7. In case if pilot lights are not lit up on the relays, ensure continuity and terminal tightening for the wires: [5.27](#) [5.26](#) [5.25](#) [5.24](#) [6.15](#) [6.14](#) [6.13](#) [6.12](#)

2.7 Heating elements (EK1-EK6)

1. Unplug the machine.
2. Ensure the resistance between (1)/VS1 and (1)/VS3 is about 8 Ω . IF it reads about 12 Ω , or OL:
 - 2.1. Ensure continuity and terminal tightening for the wires: [1.18](#) [1.20](#) [2.16](#) [3.6](#)
 - 2.2. Ensure the resistance of EK1, EK2, EK3 is about 12 Ω each. IF short or open circuit, replace fault heating element.
3. Ensure the resistance between (1)/VS2 and (1)/VS4 is about 8 Ω . IF it reads about 12 Ω , or OL:
 - 3.1. Ensure continuity and terminal tightening for the wires: [1.19](#) [1.21](#) [2.17](#) [3.7](#)
 - 3.2. Ensure the resistance of EK4, EK5, EK6 is about 12 Ω each. IF short or open circuit, replace fault heating element.

4. Ensure there is no ground fault between ground and any of [1.18](#) [1.19](#) [2.14](#) [2.15](#) [3.5](#) [3.4](#) IF found, replace fault heating element.

2.8 Power supply unit (PSU)

1. Set the main switch to CAMEL.
2. Ensure 230 VAC presents between (L)/PSU and (N)/PSU. IF voltage DOES NOT present:
 - 2.1. Ensure proper power supplied to the machine.
 - 2.2. Check QF circuit breaker.
 - 2.3. Ensure continuity and terminal tightening for the wires: [1.10](#) [1.9](#) [1.8](#) [1.2](#) [1.1](#) [2.6](#) [2.5](#) [2.9](#) [2.2](#) [2.1](#)
3. Ensure 24 VDC presents between (24V)/PSU and (0V)/PSU. IF voltage DOES NOT present, replace PSU.

2.9 Proximity sensors (BL1, BL2)

NOTE: Each sensor trips whenever a steel pin is placed in front of the sensor (BL1 when kettle is in upright position, BL2 when the kettle is in dumped position). A suitable ferrous metal item (screwdriver for example) might be used for testing the sensors.

1. Ensure both sensors are properly fixed in their places.
2. Ensure PSU is ok.
3. Set the main switch to CAMEL.
4. Ensure X4 indicator on DC1 is lit up whenever the pin or screwdriver is placed in front of BL1. IF NOT, check continuity and terminal tightening for the wires: [5.20](#) [6.0](#) [5.13](#)
5. Ensure X5 indicator on DC1 is lit up whenever the pin or screwdriver is placed in front of BL2. IF NOT, check continuity and terminal tightening for the wires: [5.21](#) [6.1](#) [5.14](#)

2.10 Contactor (KM2)

1. Unplug the machine.
2. Ensure the plunger of contactor can be smoothly pushed down with a suitable tool (screwdriver, for example).
3. Plug the machine in. Ensure the emergency stop switch is released. Set the main switch to CAMEL.
4. Ensure 208 VAC presents at (1)/KM2, (3)/KM2, (5)/KM2. IF voltage DOES NOT present:
 - 4.1. Ensure 208 VAC presents at (2)/KM2, (4)/KM2, (6)/KM2. IF voltage DOES NOT present:
 - 4.1.1. Check SA1 switch.
 - 4.1.2. Ensure continuity and terminal tightening for the wires: [1.2](#) [1.1](#) [1.0](#) [2.2](#) [2.1](#) [2.0](#) [3.2](#) [3.1](#) [3.0](#)
 - 4.1.3. Check that QF is ok and in ON position.
 - 4.2. Ensure 208 VAC presents at (A1)/KM2 and (A2)/KM2. IF voltage DOES present, replace KM2. IF voltage DOES NOT present:
 - 4.2.1. Ensure continuity and terminal tightening for the wires: [2.4](#) [2.3](#) [2.2](#) [2.1](#) [2.0](#) [1.7](#) [1.5](#) [1.4](#) [1.3](#) [1.2](#) [1.1](#) [1.0](#)

2.11 Switch (SA1)

1. Unplug the machine.
2. Disconnect wires 1.5 and 1.6 from (5)/SA1 and (2)/SA1, respectively.
3. Set the switch in OFF.

- 3.1. Ensure the status of following terminal pairs:
 - (1)/SA1 to (2)/SA1 – open;
 - (3)/SA1 to (4)/SA1 – open;
 - (5)/SA1 to (6)/SA1 – open;

IF not, replace the fault contact block.

4. Set the switch in CARMEL.

- 4.1. Ensure the status of following terminal pairs:
 - (1)/SA1 to (2)/SA1 – open;
 - (3)/SA1 to (4)/SA1 – open;
 - (5)/SA1 to (6)/SA1 – closed;

IF not, replace the fault contact block.

5. Set the switch in TWEAKING.

- 5.1. Ensure the status of following terminal pairs:
 - (1)/SA1 to (2)/SA1 – closed;
 - (3)/SA1 to (4)/SA1 – closed;
 - (5)/SA1 to (6)/SA1 – open;

IF not, replace the fault contact block.

2.12 Circuit breaker (QF)

1. Ensure 208 VAC presents at any two of (2)/QF, (4)/QF, (6)/QF. IF voltage DOES NOT present, ensure continuity of the power cord and voltage in the mains.
2. Cock up the lever of QF.
3. Ensure 208 VAC presents at any two of (1)/QF, (3)/QF, (5)/QF. IF not, replace QF.

2.13 VFD units (UZ1, UZ2)

DANGER



- **Electric shock hazard!** High voltage inside electric panel. DO NOT touch bare terminals and/or wires.
- ALWAYS unplug the machine before resistance measurement, or open circuit check, or circuit continuity check.
- Capacitors in the output circuit of the VFD might maintain high voltage at output terminals U, V, W for up to 10 minutes after power cut off.

Mixer drive VFD unit (UZ1)

1. Plug the machine in. Set the main switch to CARMEL.
2. Ensure UZ1 display is lit up. IF not, ensure 208 VAC presents between any two of (R)/UZ1, (S)/UZ1, and (T)/UZ1. IF voltage DOES present, BUT display remains black, replace the VFD unit. IF voltage DOES NOT present:
 - 2.1. Ensure continuity and terminal tightening for the wires: [2.11](#) [2.10](#) [2.2](#) [2.1](#) [2.0](#)
 - 2.2. Check KM2 contactor.
 - 2.3. Check QF circuit breaker.
3. IF display reads [OL](#) (Overload), or [OC](#) (Overcurrent), or [GFF](#) (Ground fault), check M2 motor.

Kettle drive VFD unit (UZ2)

1. Plug the machine in. Set the main switch to CARMEL.
2. Ensure the displays of UZ1 and UZ2 are lit up. IF not, ensure 208 VAC presents between any two of (R)/UZ2, (S)/UZ2, (T)/UZ2. IF voltage DOES present, BUT display remains black, replace the VFD unit. IF voltage DOES NOT present:
 - 2.1. Ensure continuity and terminal tightening for the wires: [2.10](#) [2.2](#) [2.1](#) [2.0](#)
 - 2.2. Check KM2 contactor.
 - 2.3. Check QF circuit breaker.
3. IF display reads [OL](#) (Overload), or [OC](#) (Overcurrent), or [GFF](#) (Ground fault), check M1 motor.

2.14 Motors (M1, M2)

DANGER



- Capacitors in the output circuit of the VFD might maintain high voltage at output terminals U, V, W for up to 10 minutes after power cut off.

Kettle tilt motor (M1)

1. Unplug the machine and wait at least 10 minutes.
2. Ensure resistance between every two of **U1.0** **V1.0** **W1.0** is about 10 Ω .
 - 2.1. IF it reads 30 Ω , open terminal box of the motor and re-wire the motor in delta.
 - 2.2. IF SHORT CIRCUIT, open the terminal box on the motor, repeat the measurement. IF short circuit confirmed inside the motor, replace the motor with gearbox.
 - 2.3. IF OPEN CIRCUIT, ensure continuity and terminal tightening for the wires: **U1.0**; **V1.0**; **W1.0**. Open the terminal box of the motor, repeat the measurements. IF open circuit confirmed inside the motor, replace the motor with gearbox.
3. Ensure there is open circuit (no ground fault) between the ground and any of **U1.0**; **V1.0**; **W1.0**. IF ground fault found, replace the motor with gearbox.
4. Ensure continuity and terminal tightening for **GND.7**. Replace fault motor cable.
5. Remove the grilled cap from the motor that covers the cooling impeller. Ensure the impeller can rotate as driven by hand.
 - 5.1. IF impeller cannot rotate, or can rotate only with significant effort, then take off motor with gearbox from the kettle and repeat the test. IF impeller still cannot rotate, replace the motor with gearbox.
6. Before replacing ensure the new motor is wired in delta.

Mixer motor (M2)

1. Unplug the machine and wait at least 10 minutes.
2. Ensure resistance between every two of **U2.0** **V2.0** **W2.0** is about 26 Ω .
 - 2.1. IF it reads 78 Ω , open terminal box of the motor and re-wire the motor in delta.
 - 2.2. IF SHORT CIRCUIT, open the terminal box on the motor, repeat the measurement. IF short circuit confirmed inside the motor, replace the motor with gearbox.
 - 2.3. IF OPEN CIRCUIT, ensure continuity and terminal tightening for the wires: **U2.0**; **V2.0**; **W2.0**; **U2.1**; **V2.1**; **W2.1**. Check the terminal block J for open circuit. Replace fault terminal block. Open the terminal box of the motor, repeat the measurements. IF open circuit confirmed inside the motor, replace the motor with gearbox.
3. Ensure there is open circuit (no ground fault) between the ground and any of **U2.0**; **V2.0**; **W2.0**. IF ground fault found, replace the motor with gearbox.
4. Remove the grilled cap from the motor that covers the cooling impeller. Ensure impeller can rotate as driven by hand.
 - 4.1. IF impeller cannot rotate, or can rotate only with significant effort, then take off the motor with gearbox from the mixer shaft and repeat the test. IF it still cannot rotate, replace the motor with gearbox.

- 4.2. Try to rotate the mixer manually. IF mixer cannot be rotated, replace mixer shaft assembly.
5. Before replacing, ensure the new motor is wired in delta.

2.15 Fans (MF1,MF2)

1. Set the main switch to CARMEL.
2. Ensure both fans are spinning.
3. IF fans DO NOT spin, ensure the mains voltage presents at (5)/DC3 and (6)/DC3. IF voltage DOES NOT present:
 - 3.1. Ensure continuity and terminal tightening for the wires: 1.11 1.10 1.9 1.8 1.2
1.1 1.0 2.7 2.6 2.5 2.9 2.2 2.1 2.0
 - 3.2. Check KM2 contactor.
 - 3.3. Check QF circuit breaker.
4. Unplug the machine.
 - 4.1. Check the resistance between (5)/DC3 and (6)/DC3. IF open circuit ensure continuity and terminal tightening for the wires: 1.12 2.8 and fast release connectors XS1, XS2, XP1, XP2.
5. Replace fault fan.

3 Parts list

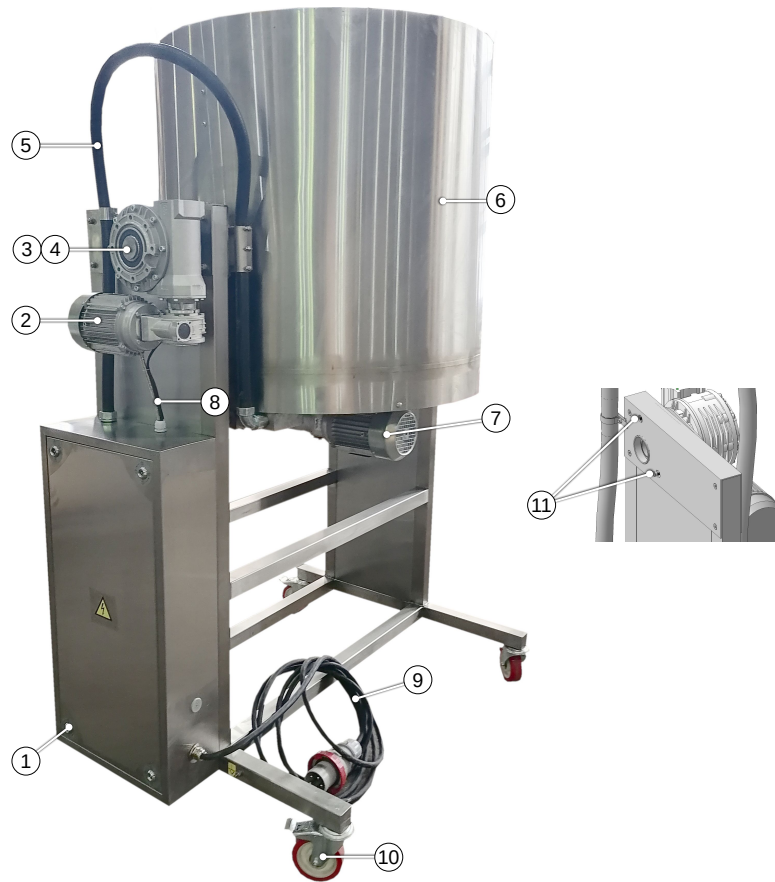

Pos.	WD sign	Item	QTY	Order no.
1	-	Lock	4	25786
2	M1	AC motor with gearbox (kettle tilt)	1	25629
3	-	Shaft fasteners set	1	26300
4	-	Shaft key	1	30705
5	-	Conduit assembled w/wires	1	26304
6	-	Kettle assembled	1	25844
7	M2	AC motor with gearbox (mixer)	1	25628
8	-	Shielded cable	2	17728
9	-	Power cord	5	30819
10	-	Swivel caster w/brake	4	24731
11	BL1, BL2	Proximity sensor	2	30674

Parts list (continued)



Pos.	WD sign	Item	QTY	Order no.
12	-	Heat insulation	6	25965
13	-	Heating coils hook-up wires set	1	30818
14	EK1-EK6	Heating coil	6	25231
15	BT2	Kettle temperature sensor	1	23226
16	BT1	Heaters temperature sensor	1	24922
17	-	Kettle lid handle	2	22870
18	-	Kettle lid (semi-round)	2	21692
19	-	Deflector w/fasteners	2	23365
20	-	Mixer assembled	1	25070
21	-	Mixer fixing nut (left-thread)	1	23386
22	-	PTFE pad	1	23360
-	-	Mixer motor terminal block (not shown)	1	23310

Parts list (continued)

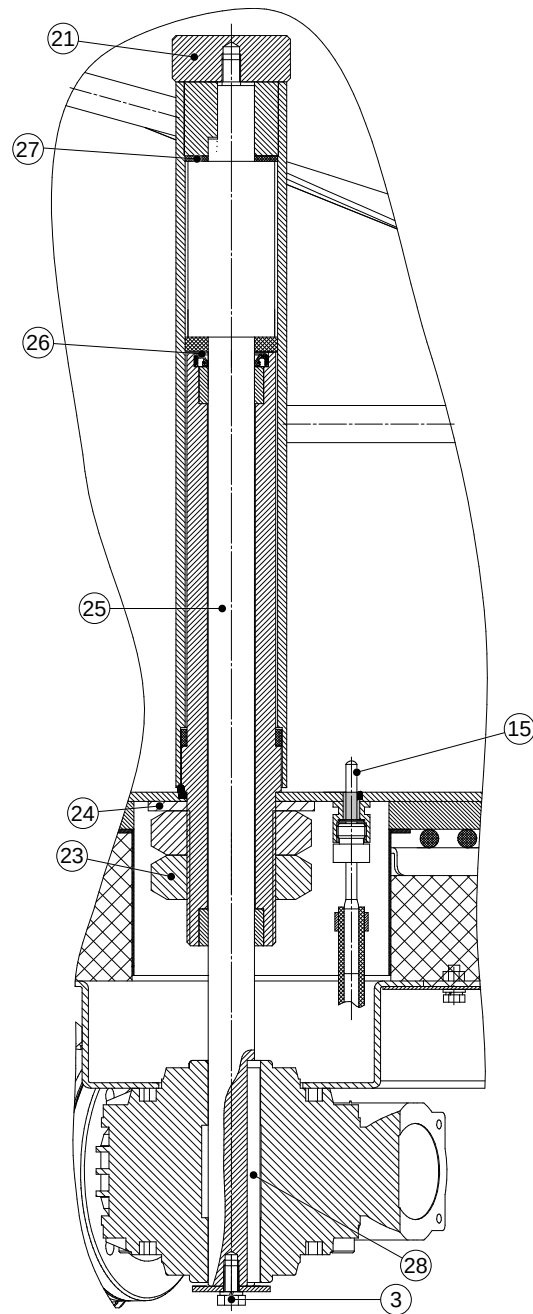

Pos.	WD sign	Item	QTY	Order no.
3	-	Shaft fasteners set	1	26300
15	BT2	Kettle temperature sensor	1	23226
21	-	Mixer fixing nut (left-thread)	1	23386
23	-	Nut M48	2	26302
24	-	Washer	1	26303
25	-	Mixer shaft repair set	1	26305
26	-	Mixer shaft sealing	1	26299
27	-	Silicone liner	1	23380
28	-	Shaft key	1	26301

Parts list (continued)



Pos.	WD sign	Item	QTY	Order no.
29	SA2	Switch 2NO	1	12978
30	-	Contact block 1NO	1	22451
31	DC3	Temperature regulator	1	25111
32	SB1-SB4	Push button	4	25121
33	-	Contact-block with LED	4	25113
34	-	Yellow protective cover	1	25473
35	SA1	Emergency stop switch	1	25138

Parts list (continued)

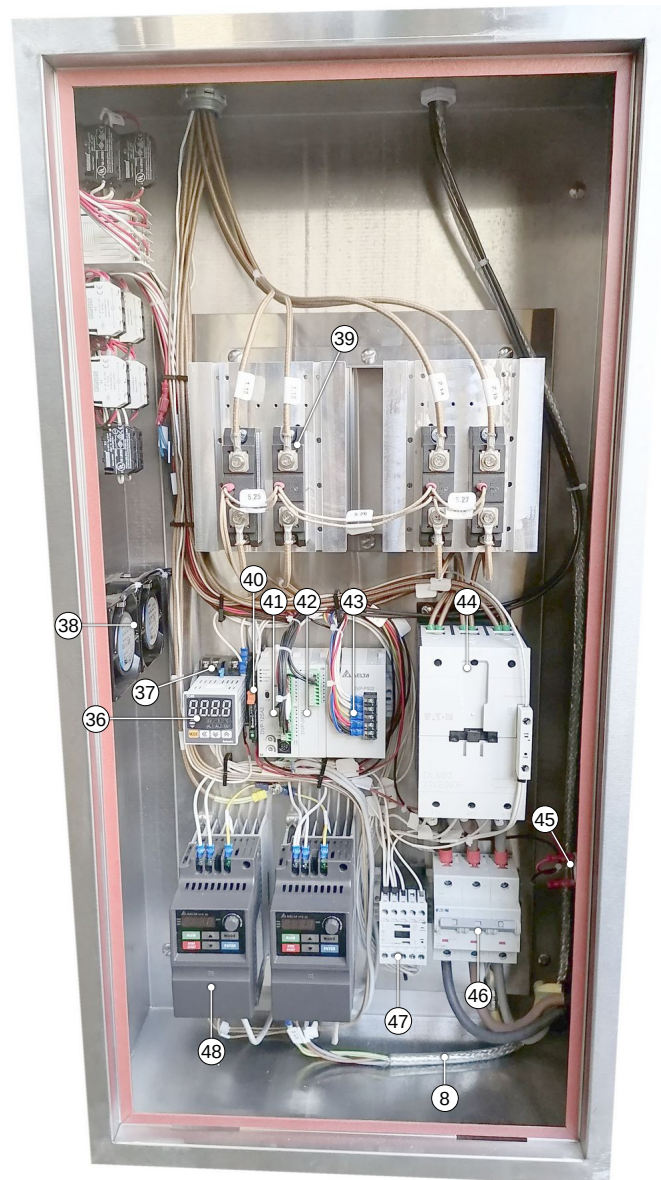

Pos.	WD sign	Item	QTY	Order no.
8	-	Shielded cable	2	17728
36	DC4	Temperature limiter	1	16848
37	-	Temperature limiter socket	1	22599
38	MF1,MF2	Fan	2	25143
39	VS1-VS4	Solid-state relay	4	26252
40	K1	Inductive relay	1	25147
41	DC1	PLC	1	25145
42	DC2	I/O extension unit	1	16324
43	TV	Power supply unit	1	15355
44	KM1	Contactora 80 A	1	26249
45	BZ	Buzzer	1	22951
46	QF	Circuit breaker 80 A	1	26251
47	KM1	Contactora 12 A	1	26250
48	UZ1, UZ2	Inverter (VFD)	2	25425