



RoboLabs

Incredible machines for fastfood & funfood

Cooling table CKPMX-03M2

230 V 50-60 Hz

User manual

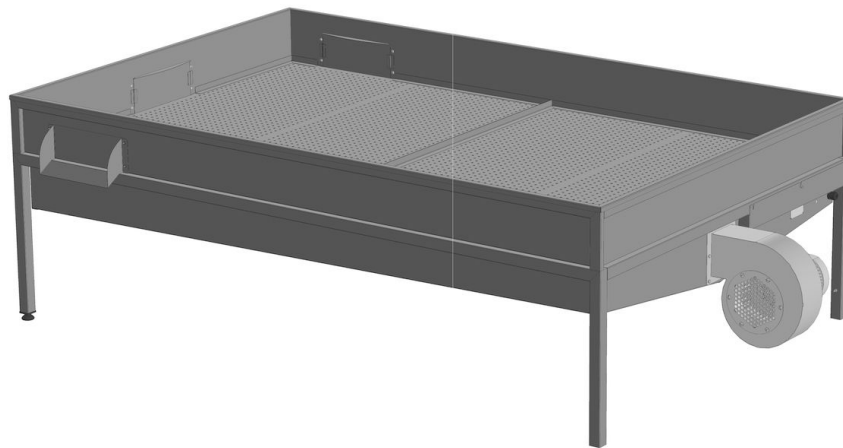

Read this manual before use and keep for future reference!

PDF version of this manual is available on www.robolabs.pro

Safety requirements



This is the safety alert symbol. It is used to alert you to potential physical injury hazards. Obey all safety messages that follow this symbol to avoid possible injury or death.

DANGER



- Not grounded equipment can cause electric shock. Power outlet **MUST HAVE** proper grounding to avoid electric shock.
- Using excessive water during cleaning can cause short circuit and electric shock. **DO NOT USE** excessive water or water jet for cleaning. **DO NOT SPILL** water on electric panels or parts.
- **ALWAYS** unplug equipment before cleaning or servicing.
- No user serviceable parts inside. **DO NOT OPEN** electric panel unless you are qualified for this.

WARNING



- Improper installation, adjustment, alteration, service or maintenance can cause property damage, injury, or death! Read and understand this manual before use.
- Only instructed personnel is allowed to operate the equipment.

Contents

1 Overview	3
1.1 Technical specifications	3
1.2 Delivery set	3
1.3 Assembling	3
1.4 Power requirements	6
1.5 Ambient and ventilation requirements	6
2 Intended use	7
2.1 Design and principle of operation	7
2.2 Operating order	7
3 Maintenance and cleaning	8
3.1 Daily cleaning	8
3.2 Conservation	8
4 Transportation and storage	9
5 Quality control check	9
6 Warranty obligations	10
7 Manufacturer details	10
A Wiring diagram	11
B Parts list	12

1 Overview

Cooling table CKPMX-03M is used for cooling caramel coated popcorn (hereinafter – “table” or “equipment”). This equipment is intended to be operated along with caramel coating machine SugarLips 100.

Not for personal use. Professional use only.

1.1 Technical specifications

Rated voltage	230 V 50-60 Hz
Rated current	5,3 A
Dimensions	2756x1663x802 mm
Weight	175 kg
Airborne noise	less than 70 dBA
Material	stainless steel

1.2 Delivery set

- 1x Blower assembled (w/ M6 fasteners)
- 1x Cable protective shroud (w/ M5 fasteners)
- 1x Perforated tray
- 1x Perforated tray with cutouts
- 1x Base frame with legs
- 1x Crumb tray baffler
- 3x Popcorn chute baffler
- 3x Popcorn chute (w/ M5 fasteners)
- 1x User manual

1.3 Assembling

1. Unpack the package carefully and check the delivery set.
2. Remove protective film from all surfaces.
3. Wipe all surfaces with a clean soft cloth dampen with dish soap. Remove soap residues. Wipe dry immediately.
4. Install the base frame at even surface. Adjust height of all four legs.
5. Attach the blower (5) to the base frame, using M6 Bolt (4), M6 Flat washer (3), M6 Spring washer (2), and M6 Nut (1), see Fig.1:

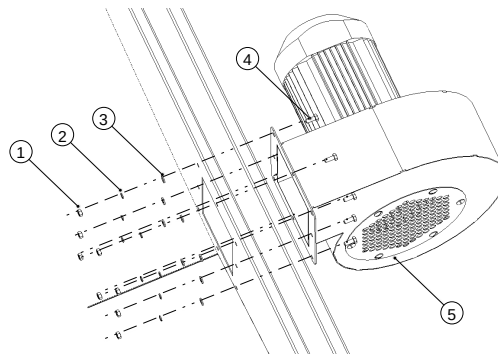

Figure 1: Blower

6. Attach the cable protective shroud (1) using M5 Flat washer (2), M5 Spring washer (3), and M5 Nut (4), see Fig.2:

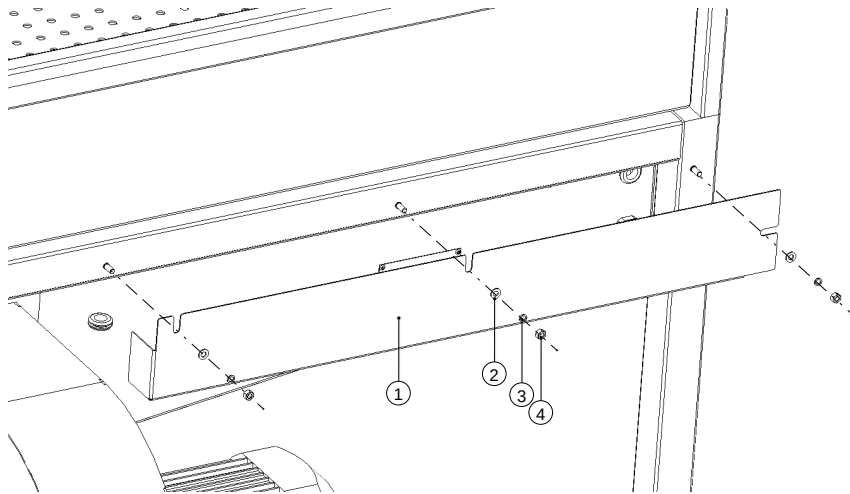



Figure 2: Cable shroud

7. Put perforated trays (1) and (3) on the supports (4), using handles (2), see Fig.3. Note three cutouts (shown by arrows) on one tray that must match popcorn chutes.

⚠ CAUTION

 • The perforated trays are heavy (21 kg each). At least two persons required to handle them.

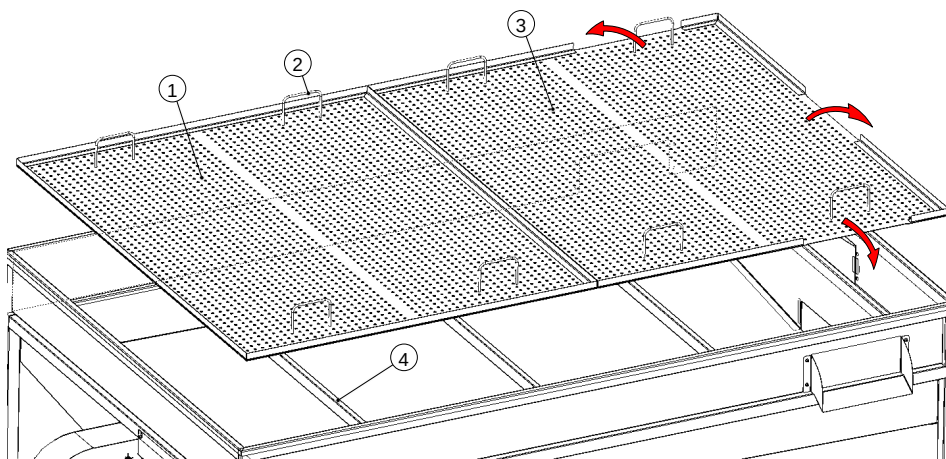

Figure 3: Perforated trays

8. Attach the popcorn chutes (1), using M5 Button head screws (2), see Fig.4.
9. Insert three popcorn chute bafflers, see Fig.5

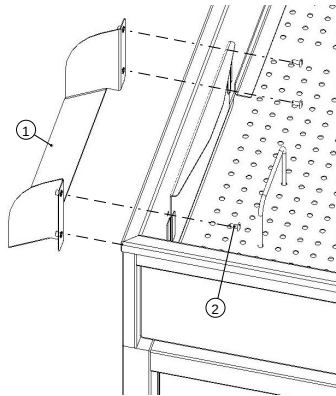

Figure 4: Popcorn chute

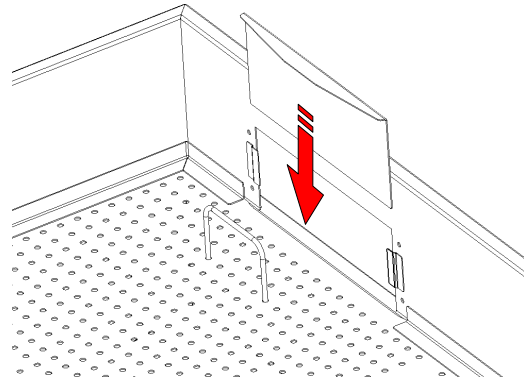

Figure 5: Popcorn chute baffler

10. Insert crumb tray baffler, see Fig.6

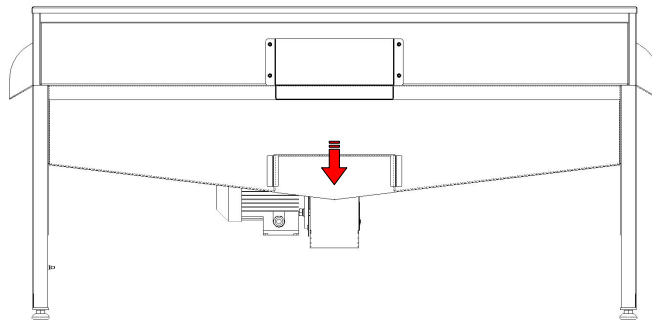

Figure 6: Crumb tray baffler

11. Plug the table in the wall outlet, see Power requirements section.
12. Turn the blower on (see Fig.8) and ensure that air blows upwards from the perforated trays. Turn the blower off.

1.4 Power requirements

DANGER



- Power outlet MUST have proper grounding to avoid electric shock.
- If supply cord damaged, it must be replaced by manufacturer, service agent, or skilled person in order to avoid hazard!
- Connections must be done by skilled electrician ONLY!

Equipotential bonding wire (up to 10 sq.mm) shall be connected to screw terminal on the base frame marked with IEC 5021 sign:



The table comes with power cord fitted with Schuko plug (CEE 7/4). Use relevant outlet.

1.5 Ambient and ventilation requirements

This equipment is designed to be operated at the ambient temperature from +5°C to +40°C (+41°F to +104°F) and relative humidity not more than 45% at 40°C (104°F) while using at altitudes not exceeding 1000 m over the sea level. The temperature decreasing is related to RH increasing, for example, 90% of RH at 20°C (68°F). This equipment MUST NOT be exposed to precipitations of any kind (rain, snow and so on).

2 Intended use

2.1 Design and principle of operation

Caramel coated popcorn is being constantly tossed by an operator on the perforated trays (1) and (2), see Fig.7. Blower (5) forces ambient air to flow from the room in housing of the table, and then through perforated trays, thus helping to cool down the product. Crumbs of caramel and popcorn is being screened through the perforation and collected in the low part of the housing, crumb tray (4). After popcorn is cooled down, operator opens the popcorn chutes (3), by removing popcorn chute bafflers, and then discharge ready-to-eat product.

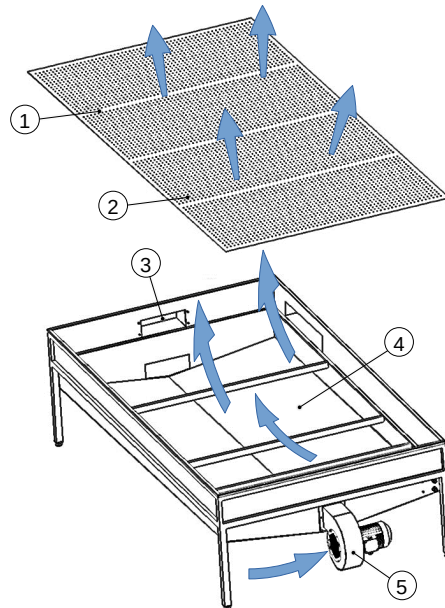

Figure 7: Principle of operation

2.2 Operating order

1. Prepare caramel coated popcorn on SugarLips 100 machine.
2. Once caramel coated popcorn is ready to be cooled and separated, set ON-OFF switch (1), see Fig.8, to ON position (I).
3. Dump coated popcorn on the table.
4. Toss popcorn with spades, allowing it to separate and cool down.
5. Once popcorn is cooled down enough, open the popcorn chute bafflers and discharge ready to eat popcorn.
6. Set the switch to OFF position (O).

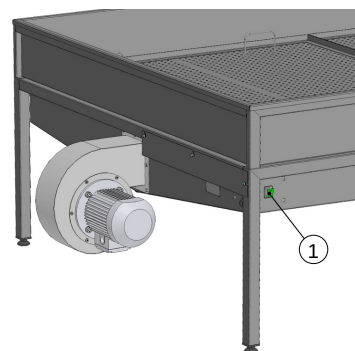

Figure 8: ON-OFF switch

3 Maintenance and cleaning

DANGER



- **ALWAYS UNPLUG** equipment before cleaning or servicing.
- **DO NOT USE** excessive water or water jet for cleaning. **DO NOT SPILL** water on electric panels or electric parts.
- Keep power cord and plug off the floor and water.

WARNING



- Use **ONLY** food grade cleaners.
- **DO NOT USE** aggressive cleaners.
- **DO NOT USE** sharp items, or abrasives for cleaning stainless steel surfaces.

CAUTION



- The perforated trays are heavy (21 kg each). At least two persons required to handle them.

The purpose of maintenance and cleaning is to keep equipment in good condition during all the lifetime and to meet safety requirements.

3.1 Daily cleaning

1. Unplug the machine. Inspect the power cord and the plug for any damages, cuts, and so on. **Damaged cord must be replaced before further use of the equipment.**
2. Remove popcorn chute bafflers and crumb tray baffler. Rinse with warm water. Wipe dry.
3. Remove perforated trays. Clean with a sponge or soft nylon bristle, use dish soap or other suitable detergent, if necessary. Remove soap residues. Wipe dry.
4. Clean the crumb tray with a sponge or soft nylon bristle, use dish soap or other suitable detergent, if necessary. Remove soap residues. Wipe dry. **NOTE: Crumb tray is not leak proof, DO NOT USE lots of water.**
5. Clean outer surfaces of the table with a clean soft cloth or sponge dampened with dish soap or other suitable detergent. Remove soap residues. Wipe dry.
6. Put the perforated trays back in place.
7. Put three popcorn chute bafflers and crumb tray baffler back in place.

3.2 Conservation

If table is not used for long time, perform the cleaning procedure.

4 Transportation and storage

The equipment may be transported by any kind of covered vehicle, in accordance with transportation rules for this kind of vehicle. Ambient temperature during the transportation and storage must be between minus 25°C and +55°C.

5 Quality control check

Cooling table, CKPMX-03M2	
Product name, model	Serial no.
The equipment is made with accordance to mandatory requirements of the state standards, actual technical documentation, and approved for use.	
QC Engineer	
STAMP HERE	
Signature	Full name
DD.MM.YYYY	

6 Warranty obligations

The manufacturer guarantees trouble-free operation of the equipment during 12 months from the date of receiving the equipment by a dealer (in accordance with transport documentation); or, in case of purchase directly through Trapeza LLC or RoboLabs Ltd., from the date of purchase, given that terms of using, transportation, and storage are met.

The warranty repair is performed upon presentation of this manual and filled warranty card with the seller's seal and the date of sale. Technical specifications of the equipment can be changed by manufacturer at any time due to improvements and/or other reasons. Technical specifications stated in this document are intended to act as a reference point, which is necessary to evaluate suitability of the equipment for the customer's needs, and are not the subject of warranty policy.

The information stated in this document has been thoroughly checked and considered as accurate one; nevertheless, the manufacturer is not responsible for any typographical errors or misprints.

Due to constant improvement of the equipment, technical specifications are subject to change without prior notice!

7 Manufacturer details

RoboLabs Ltd.
11 Industrialnaya Street, Tver, 170100 Russia
Technical support:
Email: support@robolabs.pro
Phone: +7 495 956 4000

A Wiring diagram

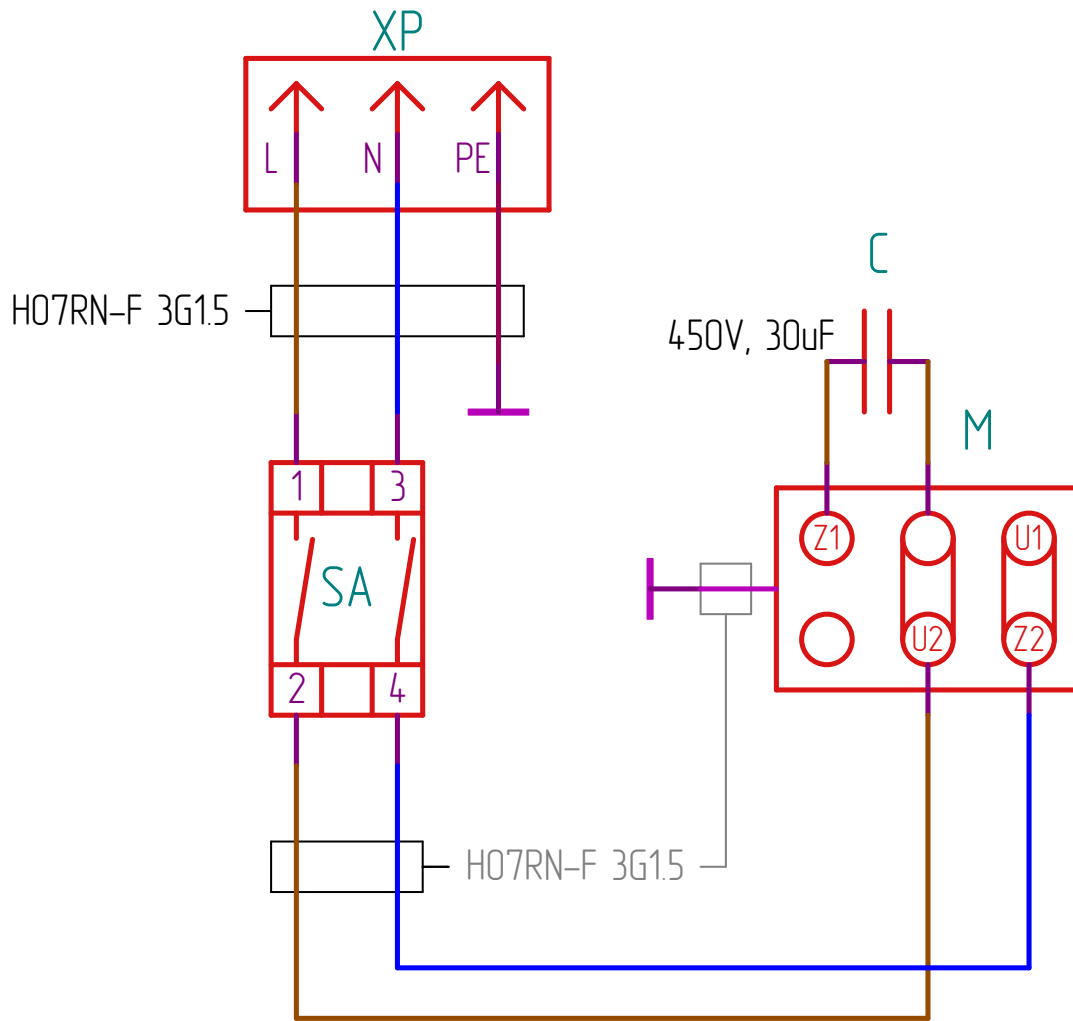

B Parts list

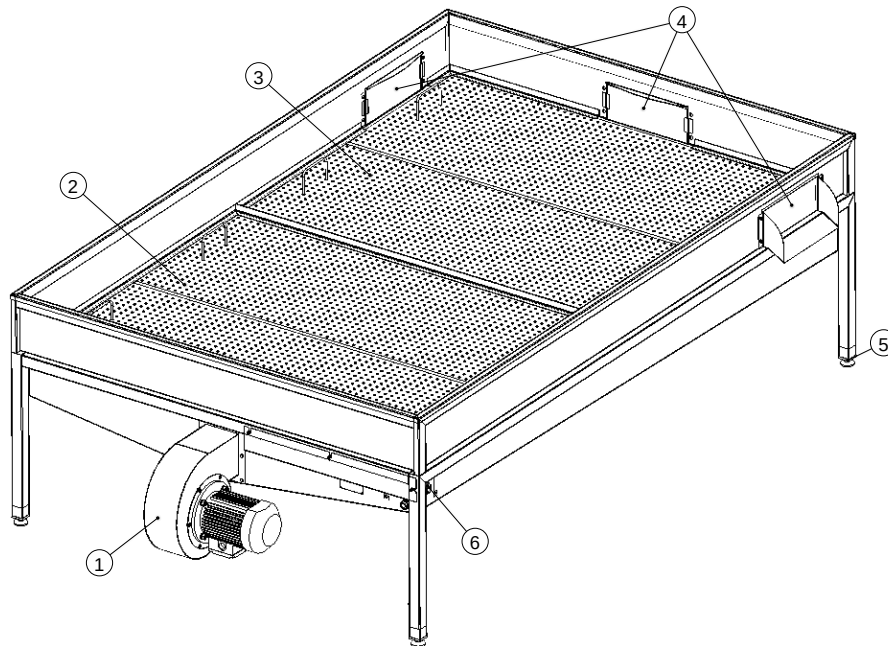

Pos.	WD sign	Item	QTY	Part no.
1	M	Blower assembled (w/ capacitor C)	1	30621
2	-	Perforated tray	1	30618
3	-	Perforated tray with cutouts	1	30619
4	-	Product chute baffle	3	30617
5	-	Adjustable leg	4	21397
6	SA	Rocker switch	1	17110

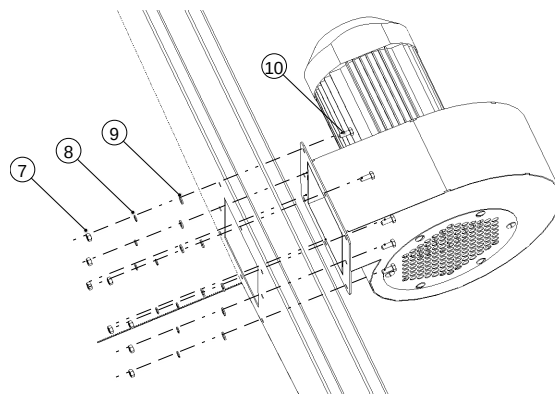

Pos.	WD sign	Item	QTY	Part no.
7	-	Nut M6 DIN 934	8	30627
8	-	Spring washer M6 DIN 127	8	25293
9	-	Flat washer M6 DIN 125	8	26059
10	-	Bolt M6x16 DIN 933	8	25290

Parts list (continued)

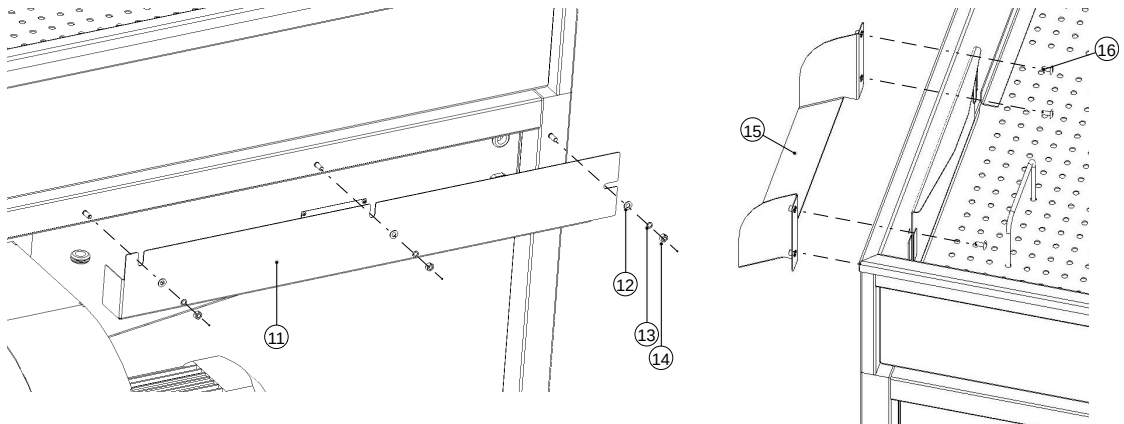

Pos.	WD sign	Item	QTY	Part no.
11	-	Cable protective shroud	1	30623
12	-	Flat washer M5 DIN 125	3	30626
13	-	Spring washer M5 DIN 127	3	30625
14	-	Nut M5 DIN 934	3	30624
15	-	Popcorn chute	3	30620
16	-	Button head screw M5x12	12	22018

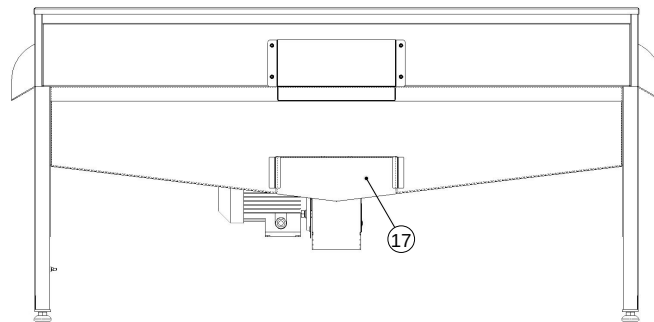

Pos.	WD sign	Item	QTY	Part no.
17	-	Crumb tray baffle	1	30616
-	XP	Power cord with Schuko plug (not shown)	1	30631